

***Inspired by Lego***



***The SiLago Method:  
Next Generation  
VLSI Architectures and Design Automation***

---

*Ahmed Hemani*

*KTH – Dept of Electronics and Embedded Systems, School of ICT, KTH.*

**Acknowledgement:**

**Nasim Farahini, Muhammad Asad, Li Shuo, Hassan Sohofi,  
Muhammad Ali Shami, Adeel Tajammul, Omer Malik,  
Anders Lansner, Christer Svensson**

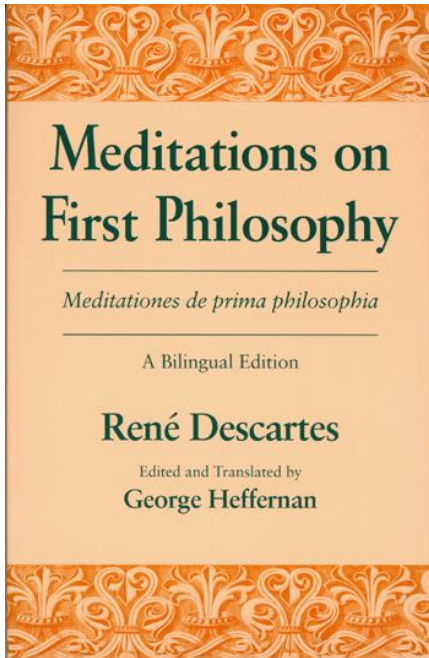

Expressed in terms  
of first 100 words

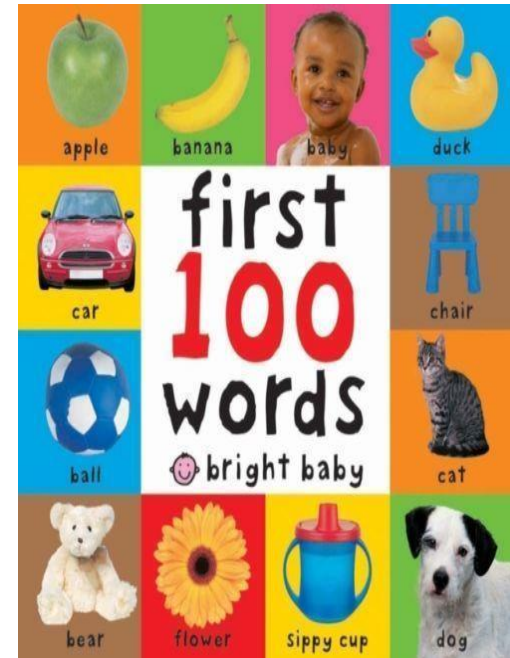

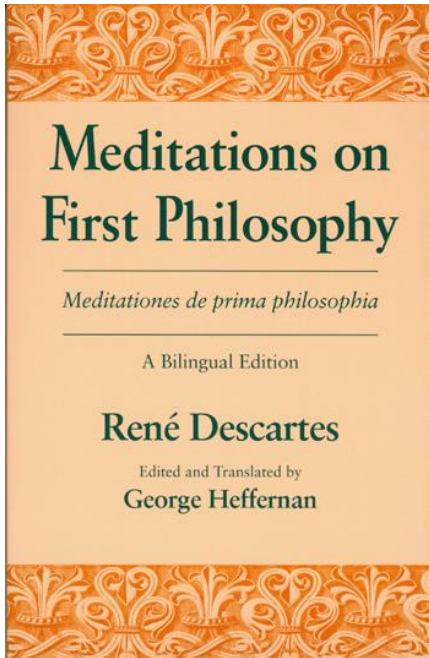

Life becomes much  
easier

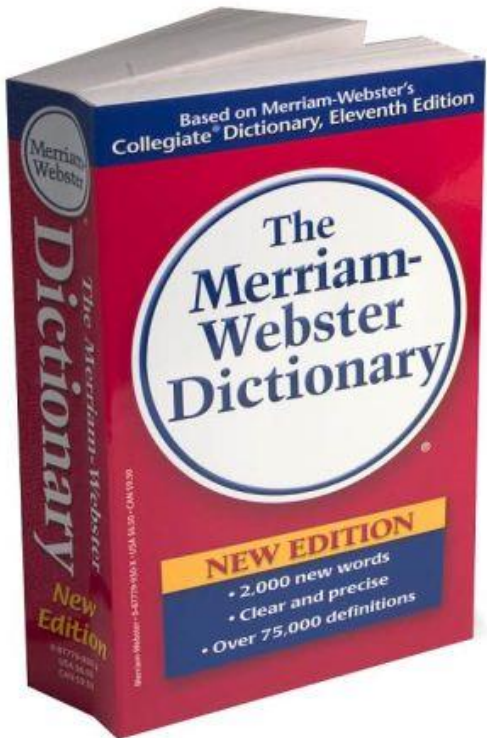

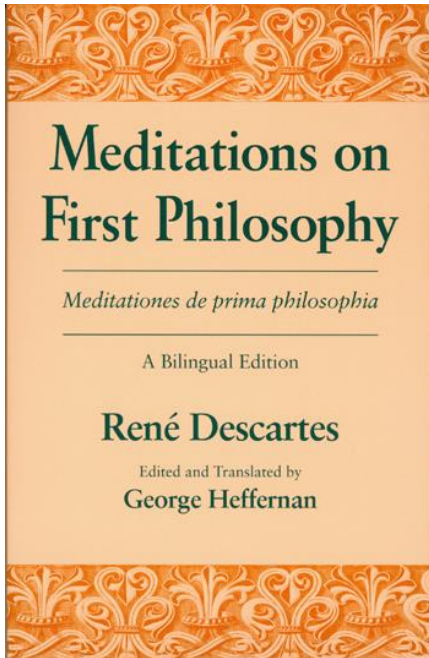

Life becomes even  
better



# *Standard Cells is too small*

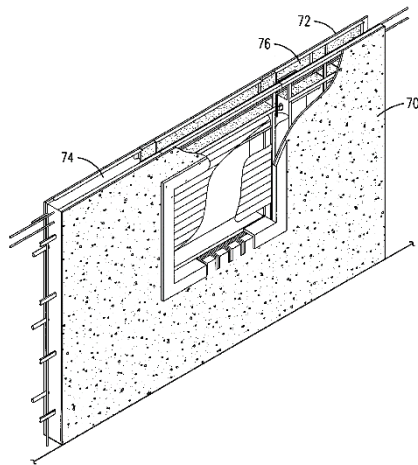

# *The First Proposition – Raise Abstraction to $\mu$ Arch level*

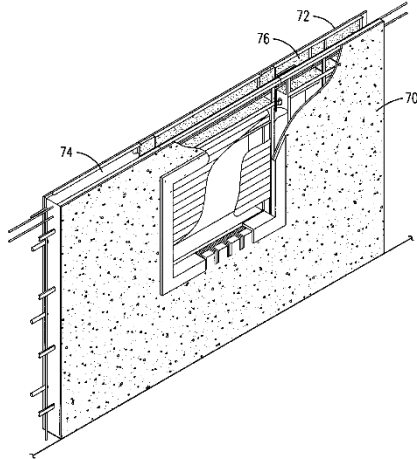

**Standard Cell**

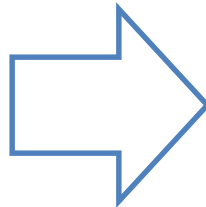

**Characterised  
boolean operations**

**4-5 orders larger than Standard Cell**

**SiLago Blocks  
Are NOT IPs – Soft or Hard**

**SiLago Block**

*(Register Files, DPUs, Switch boxes,  
Processors, SRAM banks etc.)*

**Characterised  
Micro-architectural operations**



# Need a new Structured Physical Design Discipline

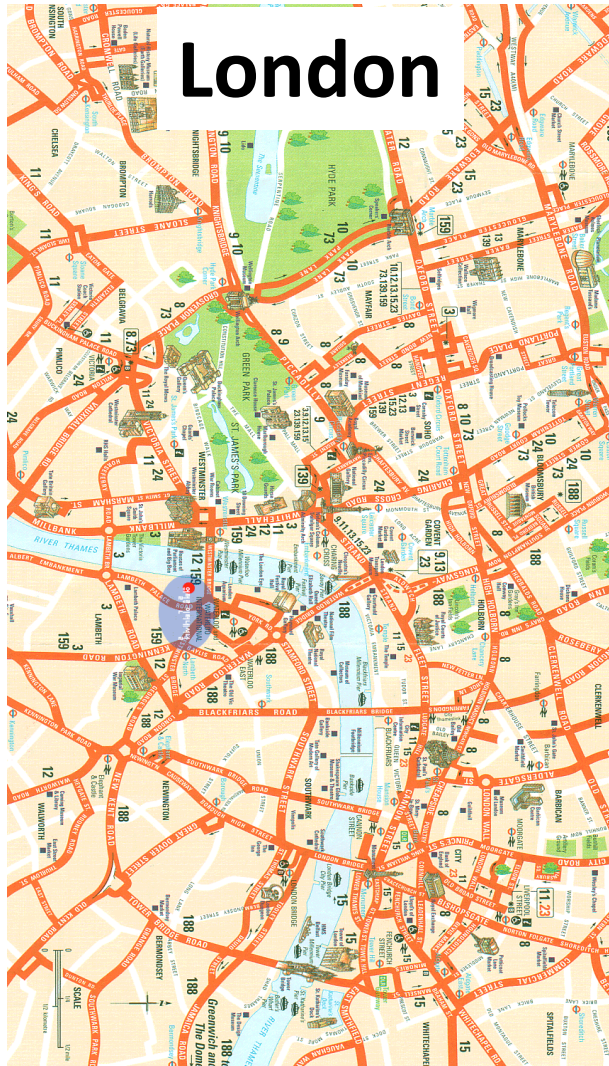

# A grid based structured layout scheme

*Traditional SOC*

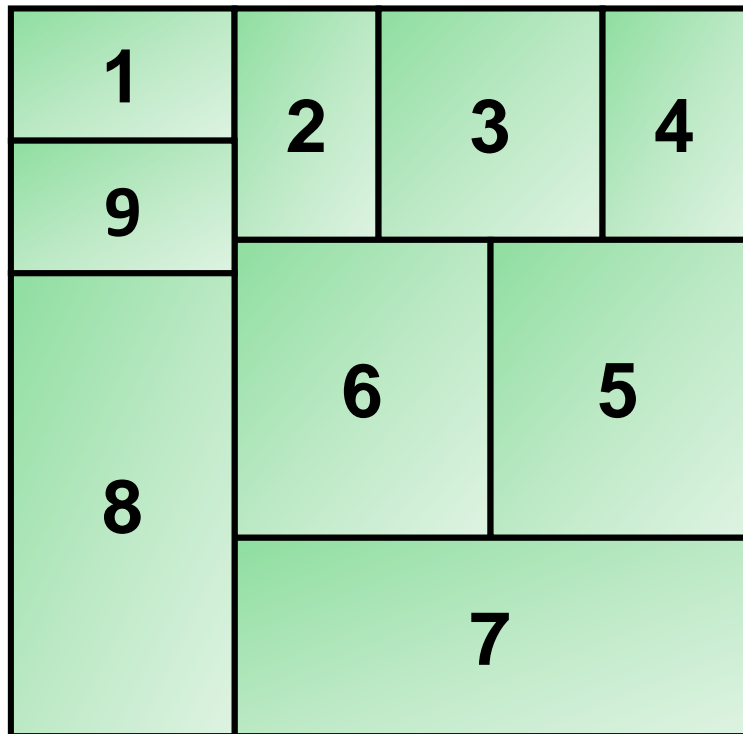

*SiLago Fabric based SOC*





# The SiLago Concepts

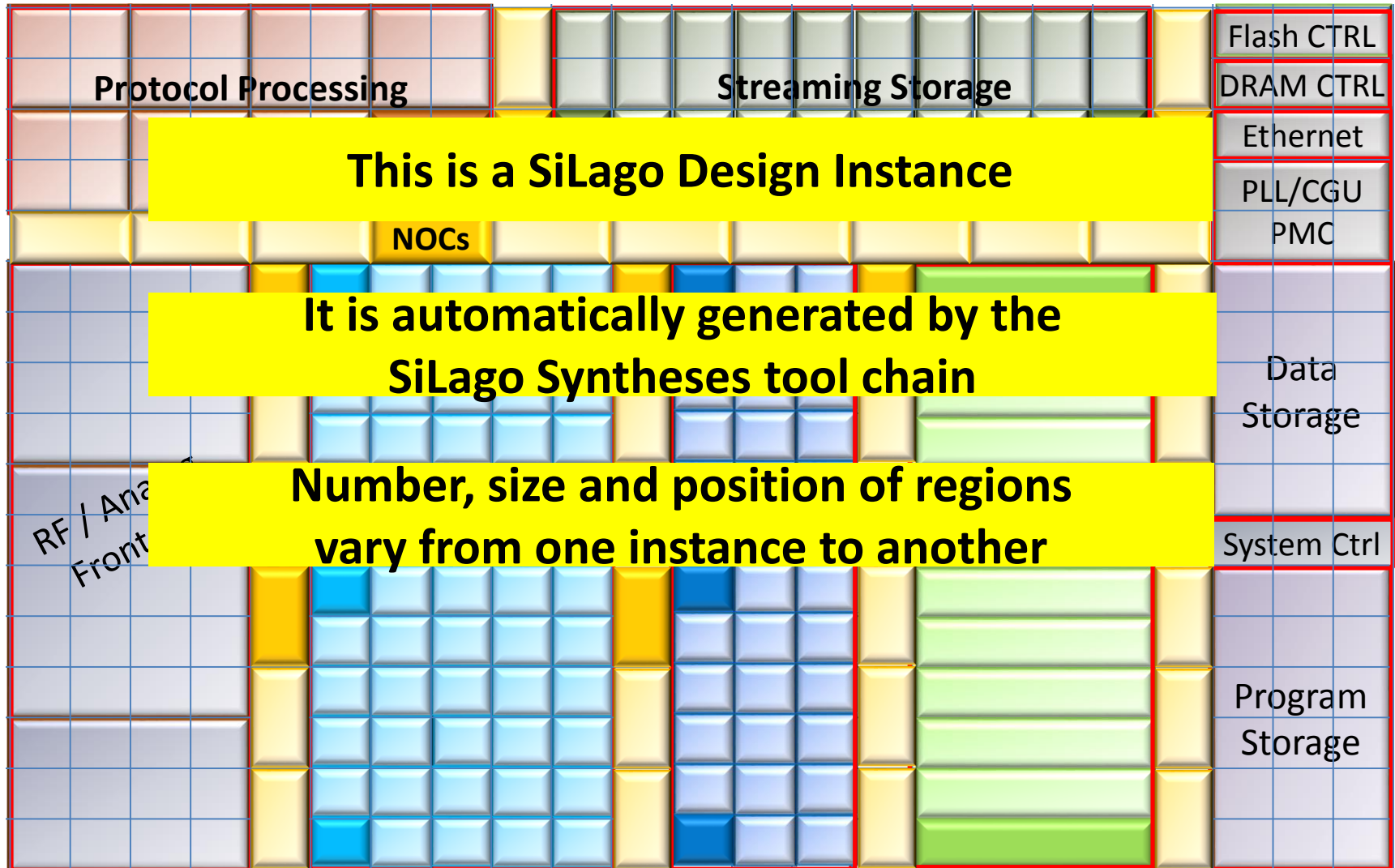

# SiLago plotted on the VLSI Evolutionary Path

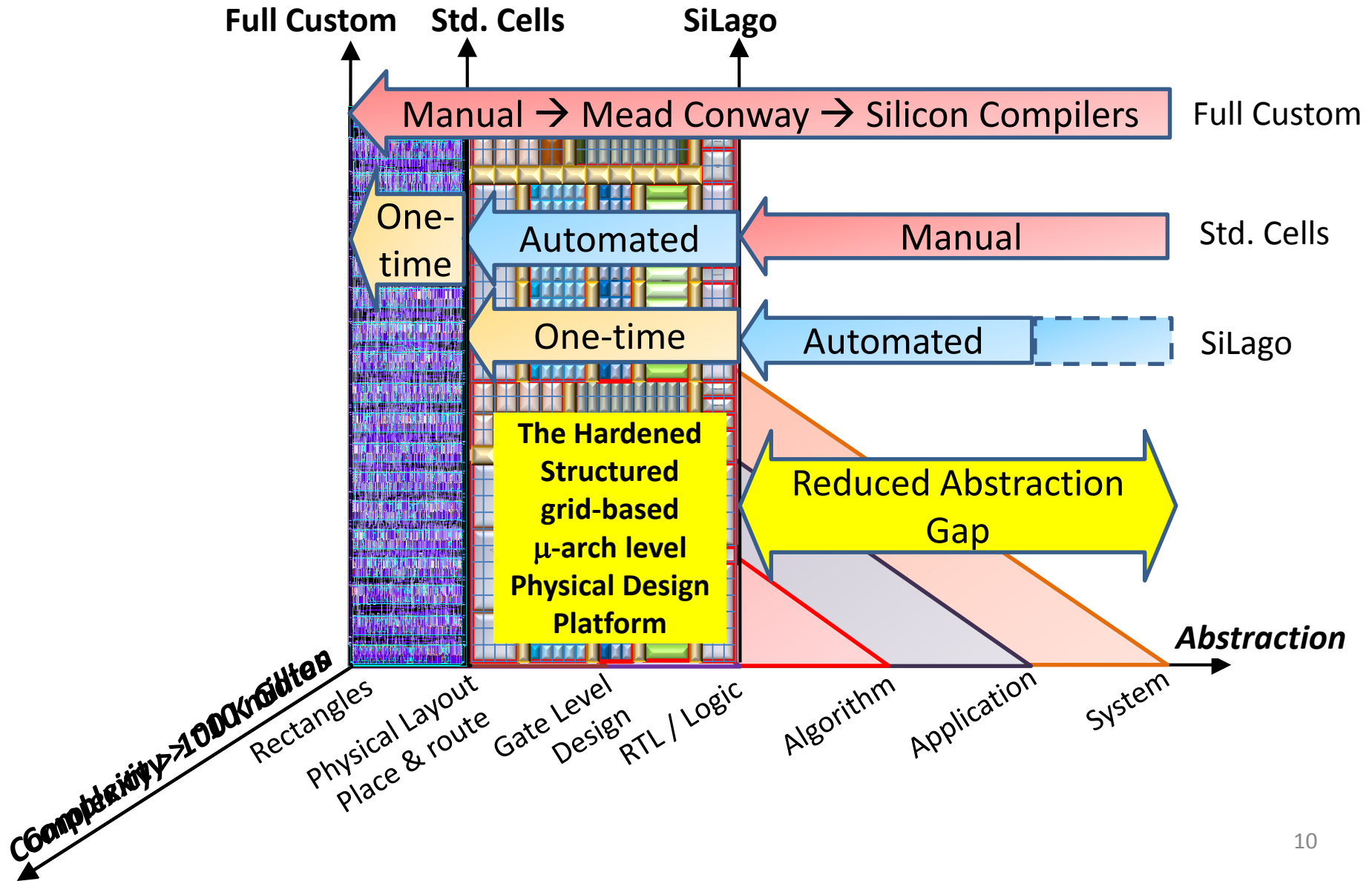

# The Challenges

## Higher Abstraction Vocabulary

Functional

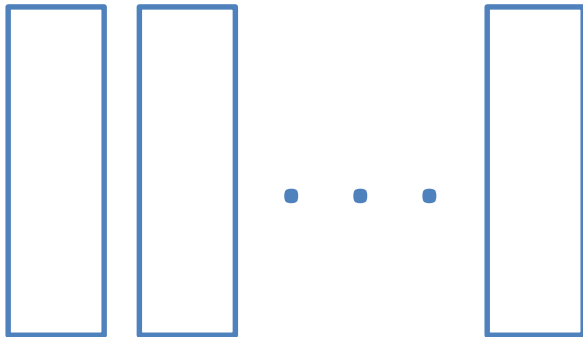

*13 Dwarfs in Berkeley Report on Landscape of Parallel Computing*

Infrastructural

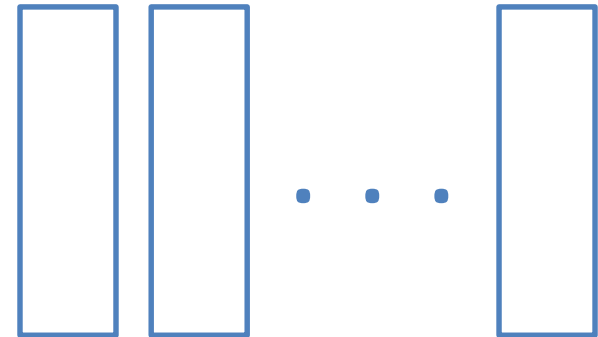

*Communication, Storage, Power Management etc.*

***A word in the Vocabulary is not a software routine but a hardened SiLago block that composes by abutment***

# *SiLago can reduce the mask development cost*



**All SiLago designs are composed of a finite number of SiLago blocks**

**All SiLago blocks can only have a finite type of neighbors**

**Each SiLago blocks's mask depending on the neighbor type can be saved as a component mask**

**The entire design mask can be composed from such component masks**



# SiLago Design Flow

